



SOLAR + ENERGY STORAGE

JIANGXI YIFA ELECTRIC POWER TECHNOLOGY SHARES CO., LTD.

Add: Zone C, Chongren County Industrial Park, Jiangxi Province.

<http://www.inter-yifa.com> E-mail: zby@yifachina.com

Tel: 0577-62608111 +8615167422211



Trill



WeChat

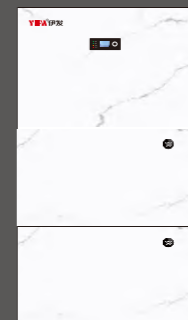

SOLAR ENERGY STORAGE

CONTENTS

ABOUT SOROTEC	1-2
PRODUCT OVERVIEW	3-4
OFF GRID INVERTER	5-12
REVO VP/VM	
REVO VM II PRO	
REVO VM IV PRO - T	
REVO VM III - T	
ENERGY STORAGE INVERTER	13-18
REVO HM	
REVO VM IV	
REVO HMT	
ALL IN ONE	19-20
REVO HESS	
ENERGY STORAGE INVERTER IP65	21-30
REVO HES	
iHESS-1P-EU	
iHESS-3P-EU	
iHESS-M	
iHESS-M-H 3P	
INDUSTRIAL AND COMMERCIAL ENERGY STORAGE INVERTER	31-38
MPG-M	
MPGS	
MPG	
SES	
ENERGY STORAGE BATTERY	39-44
SL-W SL-R	
SL-W-EU	
SL-S-EU	
SHW48500	45-46



Brief Of Introduction

Provider of Intelligent Power Grid Manufacturing and Service Integration.

Entering Chongren Industrial Park with beautiful landscape in Fuzhou in 2010, Jiangxi YIFA Electric Power Technology Shares Co., Ltd. is a national high-tech enterprise and also a listed company specialized in the development, manufacture and sales of power transmission and transformation, wind power and solar energy power equipment. With a total investment of RMB660 million, park area of 216 hou and building area of 152000m², the project is mainly intended for the design, production and sales of 110KV and 220KV ultra-high voltage oil-immersed transformers, ultra-high dry type transformers, amorphous alloy transformers, solar energy, wind power box type substations, electric energy metering boxes, transparent electricity larceny prevention electric meter boxes, etc. The 110KV and 220KV ultra-high voltage oil-immersed transformers and ultra-high dry type transformers fill the gap in Jiangxi Province and have outstanding social and economic benefits.

Following the business philosophy of treating quality as top priority, time as reputation and price as competitiveness, we are engaged in the power transmission and transformation industry, committed to the development and innovation of the electrical industry, vigorously introduce domestic and foreign advanced technical equipment and own fully automatic and standardized lean production line, Inner Mongolia 3D Research Institute's complete set of digitalized intelligent transformer testing equipment, Panasonic GIII robot welding system, Japanese plate production line and imported Germany numerical control laser cutting machine. By transforming traditional models with advanced equipment, we realize flexible automation of the manufacture process. The ERP system is implemented throughout the overall operation system management of the enterprise. Following the concept of "profession, differentiation and refinement" and the corporate spirit of "safety first and service orientation", we provide low-carbon and eco-friendly, small size and intelligent electric appliance products with high technical content for domestic and foreign users to jointly create a "multi-win" situation which makes the society satisfied and customers benefit from it.

We constantly insist on the concept of "safety first and service orientation". By absorbing new ideas, maintaining strictly quality standards and tracking services comprehensively, we insist on manufacturing high-quality products. We follow the mission of "innovation, practice, integrity, service and benefit". We attach great importance to the brand strategy, insist on marketing innovation and are listed among top players in the electrical industry. The Company is the chairman organization of Jiangxi Power Industry Association, famous brand, famous product in Jiangxi Province, an AAA company abiding by contract and valuing credit in Jiangxi Province, the partner of Shenyang High-voltage Electric Appliance Research Institute and specified supplier for centralized scale procurement by State Grid. Our products are widely used in such critical projects as high-speed railway, urbanization construction, oilfields, thermal power, hydropower, airports, iron and steel companies, gas supply and heat supply, etc. and sold to such many countries and regions as Japan, America, Russia, Southeast Asia, Middle East and Africa. We follow the concept of customer orientation and obtain good market reputation in China and foreign countries.

The Company is certified with the ISO9001 quality management system and kept well and effectively operating and all of our products are certified with "CCC" and have test reports by authoritative testing agencies. The Company successively invested a huge amount of funds in the construction of the national technical development center where best technical elites home and abroad were centralized, vigorously introduced advanced domestic and foreign technology and equipment, established good partnership with multiple domestic scientific research institutes and colleges and universities for the purpose of achieving the leading level in the world.

On the present day when optimized energy allocation and optimal energy utilization is proactively advocated all over the world, the Company endeavors great efforts to develop sustainable power energy following the philosophy of technology, environmental protection, energy conservation and low carbon. Technology guarantees quality and passion makes dreams come true. Facing the tide of economic globalization, YIFA employees will endeavor to implement explorations, make continuous progresses, advance with the times and promote the sustainable, healthy, rapid and harmonious development of energy, environment and enterprises. We hope that domestic and foreign colleagues and massive customers will cooperate with and support each other as always and work hard to build an eco-friendly power industry!

JIANGXI YIFA ELECTRIC POWER TECHNOLOGY SHARES CO., LTD.

Residential Energy Storage Inverter

OFF GRID INVERTER



REVO VP/VM

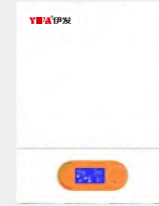

REVO VM II PRO



REVO VM IV PRO-T



REVO VM III-T

ENERGY STORAGE INVERTER



REVO HM



REVO VM IV



REVO HMT



ALL IN ONE REVO HESS

ENERGY STORAGE INVERTER

IP65 EU



REVO HES



iHESS-1P-EU



iHESS-3P-EU

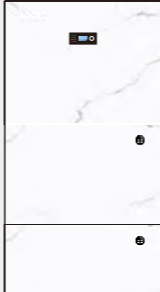

ALL IN ONE iHESS-M/HM

INDUSTRIAL AND COMMERCIAL ENERGY STORAGE INVERTER



MPG-M



MPGS



MPG



SES



SHW

ENERGY STORAGE BATTERY



SL-R



SL-R



SL-W



SL-W-EU

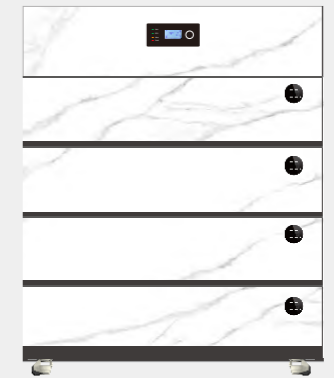

SL-S-EU

REVO VP/VM series

Hybrid Energy Storage Inverter

1-5KW



MPPT
Pure sine wave MPPT solar inverter
Built-in 60/65A MPPT solar charger



Off-Grid
REVO VP/VM series is suitable for
off-grid applications.



Easy access
Equalization function

Product characteristics

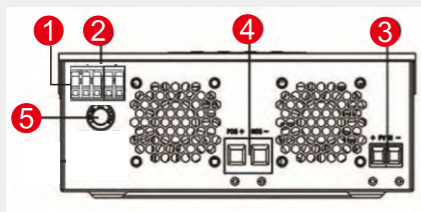

1KVA/2KVA

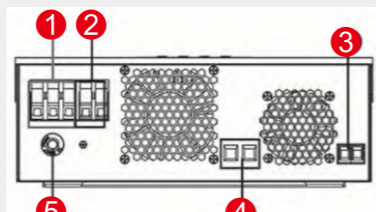

3KVA

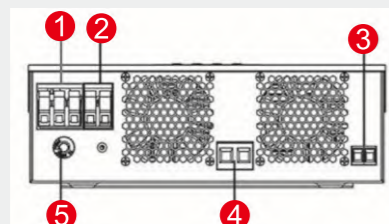

3KVA/5KVA

- ① AC input
- ② AC output
- ③ PV input
- ④ Battery input
- ⑤ Circuit breaker

OFF GRID INVERTER

Technical Specification	REVO VP 1000-12	REVO VM 1200-12	REVO VP 2000-24	REVO VM 2200-24	REVO VP 3000-24	REVO VM 3200-24	REVO VP 5000-48	REVO VM 5000-48
Rated Power	1000VA/W	1200VA/W	2000VA/W	2200VA/W	3000VA/W	3200VA/W	5000VA/W	
AC INPUT								
Voltage	230VAC							
Selectable Voltage Range	170-280VAC(For Personal Computers) ;90-280 VAC(For Home Appliances)							
Frequency Range	50Hz/60 Hz (Auto sensing)							
AC OUTPUT								
AC Voltage Regulation (Battery Mode)	230VAC ± 5%							
Surge Power	2000VA	4000VA	6000VA	10000VA				
Efficiency (Peak)	90%~93%							
Transfer Time	10ms(For Personal Computers)20ms(For Home Appliances)							
Waveform	Pure sine wave							
BATTERY								
Battery Voltage	12VDC	24VDC			48VDC			
Floating Charge Voltage	13.5VDC	27VDC			54VDC			
Overcharge Protection	16VDC	31VDC	33VDC	63VDC				
SOLAR CHARGER & AC CHARGER								
Solar Charger type	PWM	MPPT	PWM	MPPT	PWM	MPPT	PWM	MPPT
Maximum PV Array Open Circuit Voltage	55VDC	102VDC	80VDC	102VDC	80VDC	102VDC	105VDC	145VDC
Maximum PV Array Power	600W	700W	1200W	1400W	1200W	1800W	2400W	3000W
MPPT Range @ Operating Voltage	N/A	17~80VDC	N/A	30~80VDC	N/A	30~80VDC	N/A	60~115VDC
Maximum Solar Charge Current	50A	50A	50A	50A	50A	65A	50A	65A
Maximum AC Charge Current	20A	20A	20A	20A	20A	25A	60A	60A
Maximum Charge Current	50A	60A	50A	60A	70A	80A	110A	120A
GENERAL PARAMETER								
Operating Temperature	-10°C to 50°C							
Relative humidity	5% to 95% Relative Humidity(Non-condensing)							
Dimensions D x W x H (mm)	88*225*320	103*225*320	88*225*320	103*225*330	100*285*334	118.3*285*360.4	100*300*440	100*300*440
Net Weight(KG)	4.4	4.4	5	5	6.3	6.5	8.5	9.7
DISPLAY AND COMMUNICATION								
Interface	Standard: RS232							
Safety standard	EN/IEC 62109-1,EN/IEC 62109-2							

REVO VM II PRO series

Hybrid Energy Storage Inverter

1.5/2.5/3.5/5.5KW

MPPT
Pure sine wave MPPT solar inverter
BUILT-IN 80/100A MPPT solar charger

Battery
Battery equalization function extend lifecycle
Reserved communication port (RS485,CAN) for BMS

Off-Grid
REVO VM II Pro series is suitable for off-grid applications.

Easy access
High PV input voltage range
With touch buttons



With battery connected

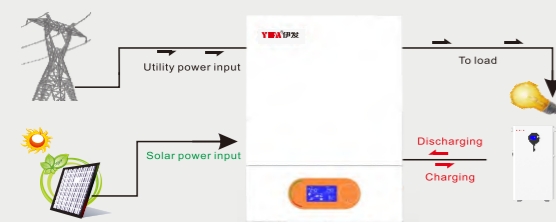

Without battery connected

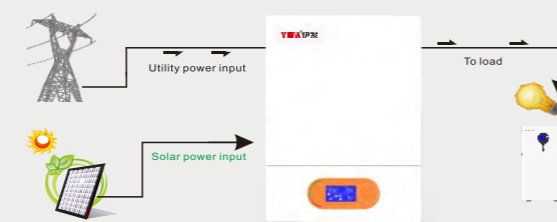

Schematic diagram

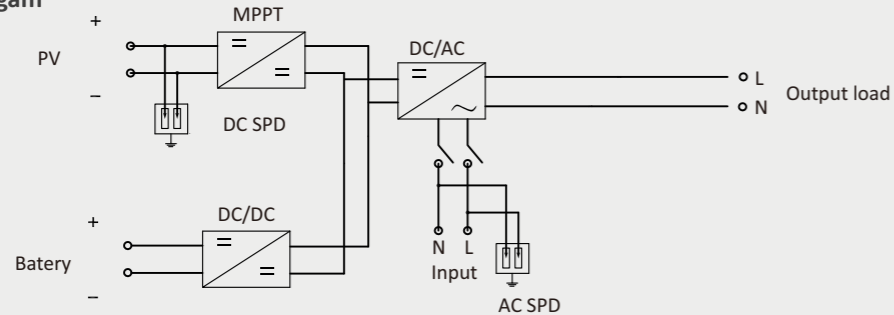

OFF GRID INVERTER

Technical Specification	REVO VM II PRO			
	1500VA/1500W	2500VA/2500W	3500VA/3500W	5500VA/5500W
Rated Power	1500VA/1500W	2500VA/2500W	3500VA/3500W	5500VA/5500W
AC INPUT				
Voltage	230VAC			
Selectable Voltage Range	170-280VAC (For Personal Computers) ; 190-280 VAC (For Home Appliances)			
Frequency Range	50Hz/60 Hz (Auto sensing)			
AC OUTPUT				
AC Voltage Regulation (Battery Mode)	230VAC ± 5%			
Surge Power	3000VA	5000VA	7000VA	11000VA
Efficiency (Peak)	up to 93.5%			
Transfer Time	10ms (For Personal Computers) ; 20ms (For Home Appliances)			
Waveform	Pure sine wave			
BATTERY				
Battery Voltage	12VDC	24VDC	48VDC	
Floating Charge Voltage	13.5VDC	27VDC	54VDC	
Overcharge Protection	16VDC	33VDC	63VDC	
SOLAR CHARGER & AC CHARGER				
Maximum PV Array Open Circuit Voltage	500VDC			
Maximum PV Array Power	2000W	3000W	4500W	5500W
MPPT Range @ Operating Voltage	90~450VDC		60~450VDC	
Maximum Solar Charge Current	80A	100A		
Maximum AC Charge Current	60A	80A		
Maximum Charge Current	80A	100A		
GENERAL PARAMETER				
Operating Temperature	-10°C to 50°C			
Relative humidity	5% to 95% Relative Humidity (Non-condensing)			
Dimensions D x W x H (mm)	348*270*95		400*300*115	
Net Weight(KG)	4	5	8.5	9
DISPLAY AND COMMUNICATION				
Communication Interface	Standard: RS232; Optional: CAN&RS485			
Safety standard	EN/IEC 62109-1, EN/IEC 62109-2			

REVO VM IV PRO-T series Hybrid Energy Storage Inverter 4/6KW

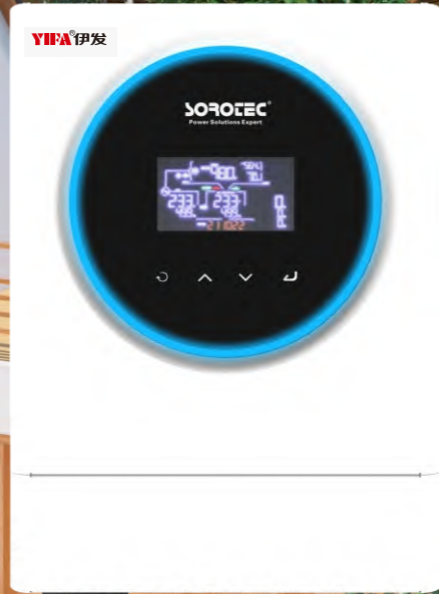

Max PV input current 27A
Designed with 27A PV input current compatible to the market trend of increased Imp of solar panel

Easy access
Two outputs for smart load management
The second output can be scheduled on & off based on setting point of battery transfer to utility

Battery
Battery equalization function extend lifecycle
Reserved communication port (RS485, CAN) for BMS

RGB Lights
Customizable status LED ring with RGB lights

Off-Grid
REVO VM IV Pro-T series is suitable for off-grid applications.

Interface
Global cloud platform mobile APP anytime and anywhere open APP, support power internet applications

With battery connected

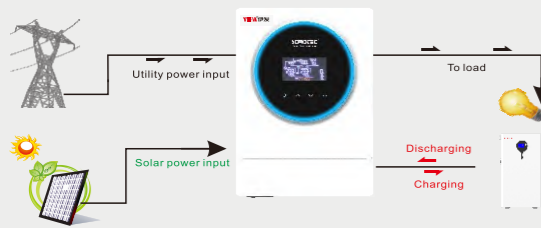

Without battery connected

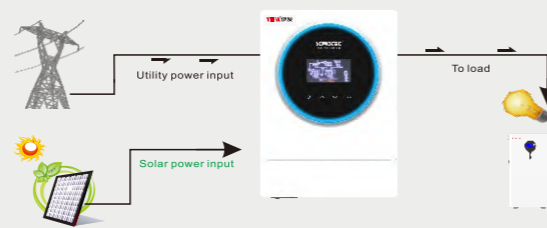

Schematic diagram

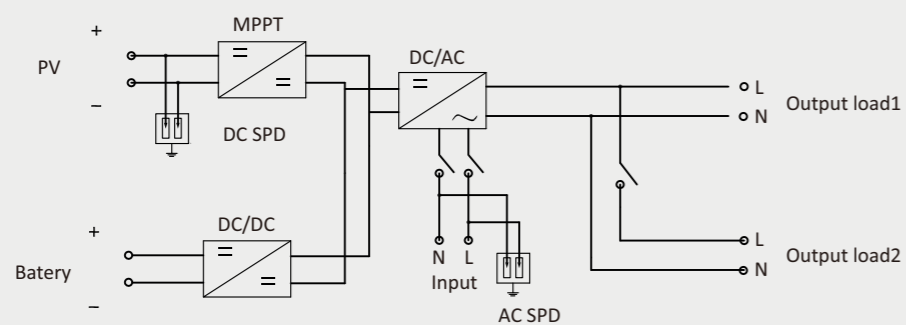

OFF GRID INVERTER

Technical Specification	REVO VM IV PRO-T series	
Rated Power	4000VA/4000W	6000VA/6000W
AC INPUT		
AC Voltage	230VAC	
Voltage Range	170-280VAC(For Personal Computers);90-280 VAC (For Home Appliances)	
Frequency Range	50Hz/60 Hz (Auto sensing)	
AC OUTPUT		
Surge power	8000VA	12000VA
Voltage regulation(Battery Mode)	230VAC±5%	
Rated frequency	50/60Hz	
Efficiency(Peak)	up to 93.5%	
Transfer Time	10ms (For Personal Computers);20ms (For Home Appliances);	
BATTERY		
Battery voltage	24VDC	48VDC
Floating Charge voltage	27VDC	54VDC
Overcharge Protection	33VDC	63VDC
Battery type	Lithium /Lead-acid	
SOLAR CHARGER & AC CHARGER		
Maximum PV Array Open voltage(V)	500VDC	
Maximum PV Array power	5000W	6000W
MPPT voltage range(V)	60~450VDC	
Maximum input current	27A	
MPPT tracker/strings	1	
Maximum solar charge current	120A	
Maximum AC charge current	100A	
Maximum charge current	120A	
PROTECTION & FEATURE		
AC overcurrent	Yes	
AC overvoltage	Yes	
Over temperature protection	Yes	
Smart load management	Yes	
GENERAL PARAMETER		
Operation temperature	0°C~ 50°C	
Relative humidity	0 ~95%(non-condensing)	
Altitude	(> 2,000m Derating)	
Dimensions D x W x H (mm)	434*311*126.5	
Net Weight(KG)	8.5	9
DISPLAY AND COMMUNICATION		
Display	Touch buttons	
Interface	Standard:RS232, CAN&RS485; Optional: WiFi ,Bluetooth	
Safety standard	EN/IEC 62109-1,EN/IEC 62109-2	

REVO VM III-T series

Hybrid Energy Storage Inverter

4/6KW

Max PV input current 27A
Designed with 27A PV input current compatible to the market trend of increased Imp of solar panel

Easy access
Two outputs for smart load management
The second output can be scheduled on& off based on setting point of battery transfer to utility

Battery
Battery equalization function extend lifecycle
Reserved communication port (RS485,CAN) for BMS

Move
Detachable LCD control module with various communications

Off-Grid
REVO VM III-T series is suitable for off-grid applications.

Interface
Global cloud platform mobile APP anytime and anywhere open APP, support power internet applications



With battery connected

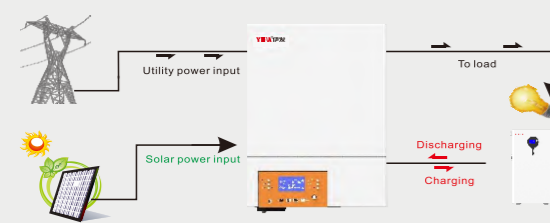

Without battery connected

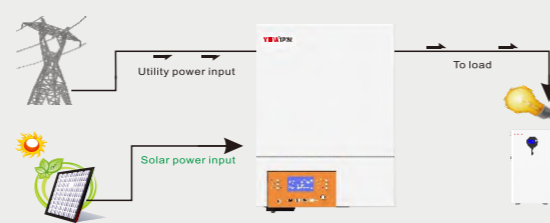

Schematic diagram

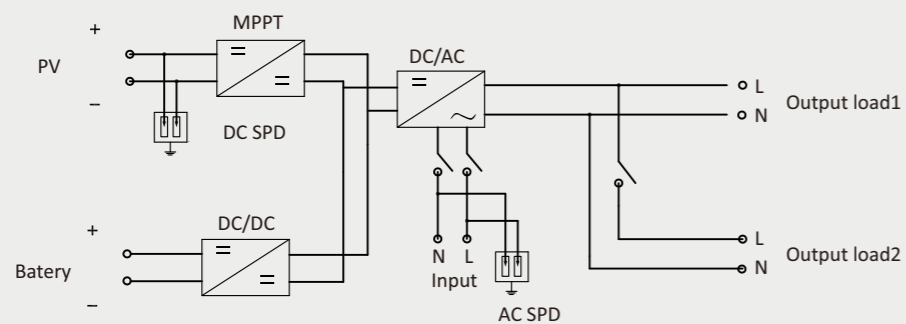

OFF GRID INVERTER



Technical Specification	REVO VM III-T series	
Rated Power	4000VA/4000W	6000VA/6000W
AC INPUT		
AC Voltage	230VAC	
Voltage Range	170-280VAC(For Personal Computers);90-280 VAC (For Home Appliances)	
Frequency Range	50Hz/60 Hz (Auto sensing)	
AC OUTPUT		
Surge power	8000VA	12000VA
Voltage regulation(Battery Mode)	230VAC±5%	
Rated frequency	50/60Hz	
Efficiency(Peak)	up to 93.5%	
Transfer Time	10ms (For Personal Computers);20ms (For Home Appliances);	
BATTERY		
Battery voltage	24VDC	48VDC
Floating Charge voltage	27VDC	54VDC
Overcharge Protection	33VDC	63VDC
Battery type	Lithium /Lead-acid	
SOLAR CHARGER & AC CHARGER		
Maximum PV Array Open voltage(V)	500VDC	
Maximum PV Array power	5000W	6000W
MPPT voltage range(V)	60~450VDC	
Maximum input current	27A	
MPPT tracker/strings	1	
Maximum solar charge current	120A	
Maximum AC charge current	100A	
Maximum charge current	120A	
PROTECTION& FEATURE		
AC overcurrent	Yes	
AC overvoltage	Yes	
Over temperature protection	Yes	
Smart load management	Yes	
GENERAL PARAMETER		
Operaton temperature	0°C~ 50°C	
Relative humidity	0 ~95%(non-condensing)	
Altitude	(> 2,000m Deratng)	
Dimensions D x W x H (mm)	466*313*136.5	
Net Weight(KG)	8.5	9
DISPLAY AND COMMUNICATION		
Display	Touch buttons	
Interface	Standard:RS232 ; Optional: WiFi ,Bluetooth	
Safety standard	EN/IEC 62109-1,EN/IEC 62109-2	

REVO HM series

Hybrid On & Off-Grid Energy Storage Solar Inverter 4/6KW



Max PV input current 27A

Designed with 27A PV input current compatible to the market trend of increased Imp of solar panel

Easy access

Two outputs for smart load management. The second output can be scheduled on & off based on setting point of battery transfer to utility



Battery

Battery equalization function extend lifecycle. Reserved communication port (RS485, CAN) for BMS



Protect

Built-in anti-dust kit for harsh environment. AC overcurrent, AC overvoltage, over temperature protection



On-Grid and Off-Grid

REVO HM series is suitable for on-grid and off-grid applications.



Interface

Global cloud platform mobile APP anytime and anywhere open APP, support power internet applications

With battery connected

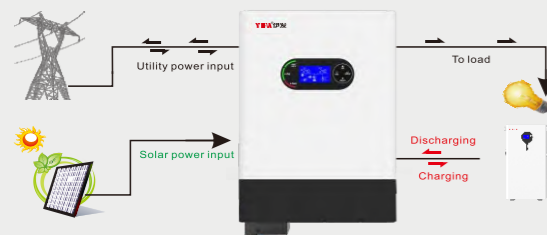

Without battery connected

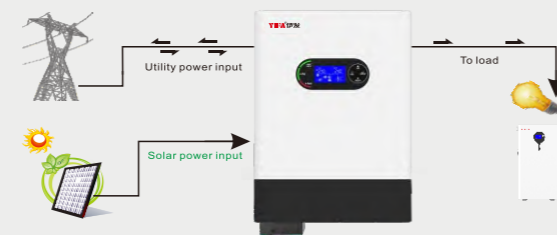

Single phase output up to 36KW using 6units

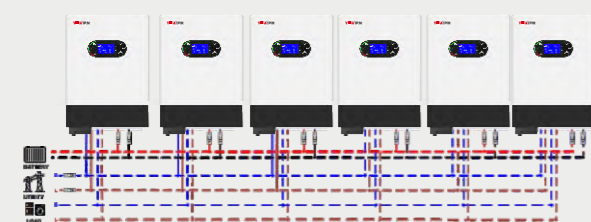

Three phase output using either 3units(18kw)or max 6units(36kw)

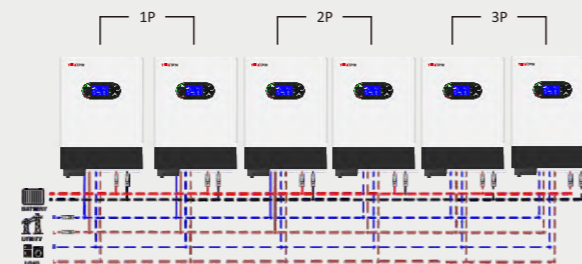

ENERGY STORAGE INVERTER

Technical Specification	REVO HM series	
Rated Power	4000VA/4000W	6000VA/6000W
AC INPUT		
AC Voltage	230VAC	
Voltage Range	170-280VAC(For Personal Computers);90-280 VAC (For Home Appliances)	
Frequency Range	50Hz/60 Hz (Auto sensing)	
AC OUTPUT		
Surge power	8000VA	12000VA
Voltage regulation(Battery Mode)	230VAC±5%	
Rated frequency	50/60Hz	
Efficiency(Peak)	up to 93.5%	
Transfer Time	10ms (For Personal Computers);20ms (For Home Appliances);	
BATTERY		
Battery voltage	24VDC	48VDC
Floating Charge voltage	27VDC	54VDC
Overcharge Protection	33VDC	63VDC
Battery type	Lithium /Lead-acid	
SOLAR CHARGER & AC CHARGER		
Maximum PV Array Open voltage(V)	500VDC	
Maximum PV Array power	5000W	6000W
MPPT voltage range(V)	60~450VDC	
Maximum input current	27A	
MPPT tracker/strings	1	
Maximum solar charge current	120A	
Maximum AC charge current	100A	
Maximum charge current	120A	
PROTECTION & FEATURE		
AC overcurrent	Yes	
AC overvoltage	Yes	
Over temperature protection	Yes	
Smart load management	Yes	
On Grid	Yes	
Parallel Function	Yes (optional)	
GENERAL PARAMETER		
Operaton temperature	0°C~ 50°C	
Relative humidity	0 ~95%(non-condensing)	
Altitude	(> 2,000m Derating)	
Dimensions D x W x H (mm)	434*311*126.5	
Net Weight(KG)	8.5	9
DISPLAY AND COMMUNICATION		
Display	Touch buttons	
Interface	Standard:RS232,CAN&RS485 ; Optional: WiFi ,Bluetooth	
Safety standard	EN/IEC 62109-1,EN/IEC 62109-2	

REVO VM IV series

Hybrid On & Off-Grid Energy Storage Solar Inverter
3.6/5.6/8/11KW

MPPT
Built-in two MPPT(8KW-10KW), with wide input range:120~450VDC

Battery
Battery equalization function extend lifecycle
Reserved communication port (RS485,CAN) for BMS

On&Off-Grid
REVO VM IV series is suitable for on&off-grid applications.

Easy access
Communication WIFI or bluetooth
Touchable button with large 5" colorful LCD



With battery connected

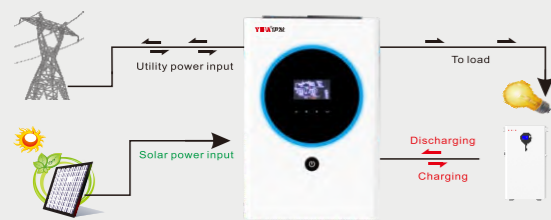

Without battery connected

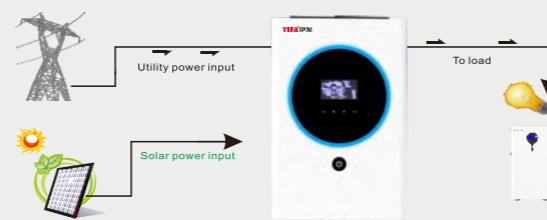

Schematic diagram

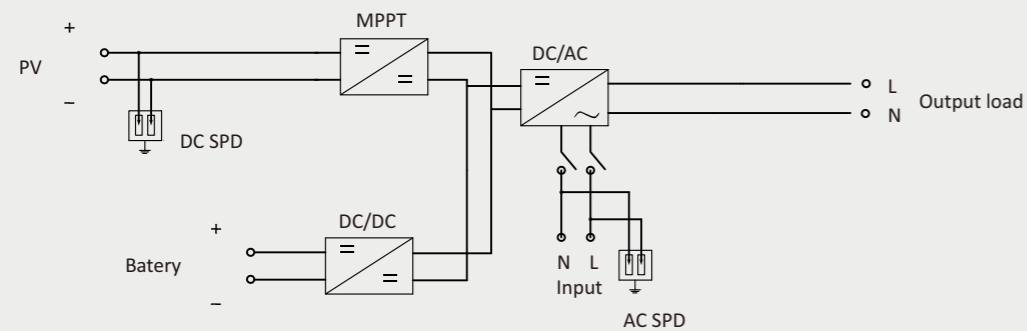

ENERGY STORAGE INVERTER

Technical Specification	REVO VM IV series			
Rated Power(W)	3600	5600	8000	11000
AC INPUT				
Nominal Voltage(VAC)	230			
Voltage range(VAC)	120-280			
Frequency range(Hz)	50/60			
AC OUTPUT				
Surge power	7200	11200	16000	22000
Output voltage(VAC)	220/230/240			
Output wave form	Pure sine wave			
Rated Frequency(Hz)	50/60			
Efficiency	up to 93.5%			
Transfer time	10ms typical (narrow range); 20ms typical (wide range)			
BATTERY				
Nominal DC voltage(VDC)	24		48	
Floatng charge voltage(VDC)	27		54	
Overcharge protecton(VDC)	31	63	60	63
Battery type	Lithium & Lead-acid			
SOLAR CHARGER & AC CHARGER				
Max. PV array open circuit voltage(VDC)	500			
Max. PV array power(W)	5500		4000*2	5500*2
MPPT input voltage range@operatng (VDC)	90-450			
Max. input current(A)	18	18	18*2	27*2
Max. solar charging current(A)	120			
Max. AC charging current(A)	100		120	150
Max. charging current(A)	120			
DISPLAY & INTERFACE				
Parallel function	up to 6 units			
Communication	Standard:RS232,CAN&RS485 ; Optional: WiFi ,Bluetooth			
Display	5' colorful LCD			
ENVIRONMENT				
Humidity	0~90% RH (No Condensing)			
Operating Temperature	0 to 50°C			
Net Weight(KG)	9	10	18.8	20
Dimensions D x W x H (mm)	302*500*132.5		420*561.6*152.4	

REVO HMT series

Hybrid On & Off-Grid Energy Storage Solar Inverter

4/6KW

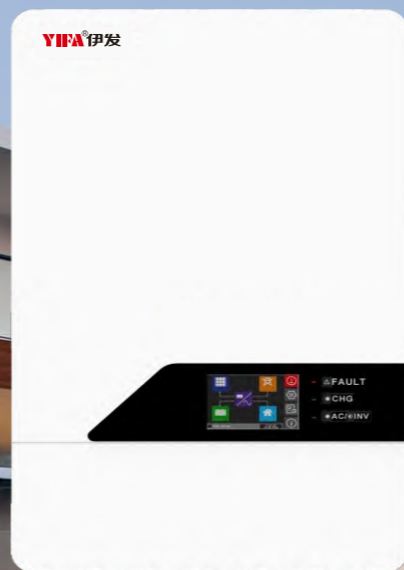

On-Grid and Off-Grid
REVO HMT series is suitable for on-grid and off-grid applications.

Easy access
Accessible through a LCD touch screen and through the web.
Two outputs for smart load management

Remote Monitoring
Control and monitor your smart system on the move via our monitoring App and website

BMS
BMS Communicator for lithium battery

Safe
Built-in anti-dust kit for harsh environment
AC overcurrent, AC overvoltage, over temperature protection

Flexible Rate Tariff
Charge from the grid at off-peak time when energy is cheaper, and discharge at peak time when energy is more expensive.

Product characteristics



- A: AC OUTPUT
- B: AC INPUT
- C: COM
- D: PV INPUT
- E: ON/OFF
- F: DC INPUT
- G: PARALLEL CONNECTION

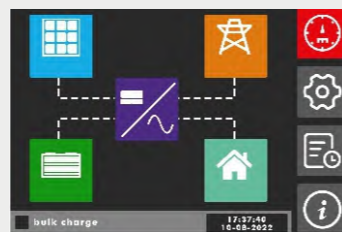

LCD touch screen

Circuit block diagram

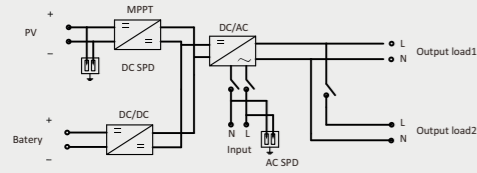

Product application diagram

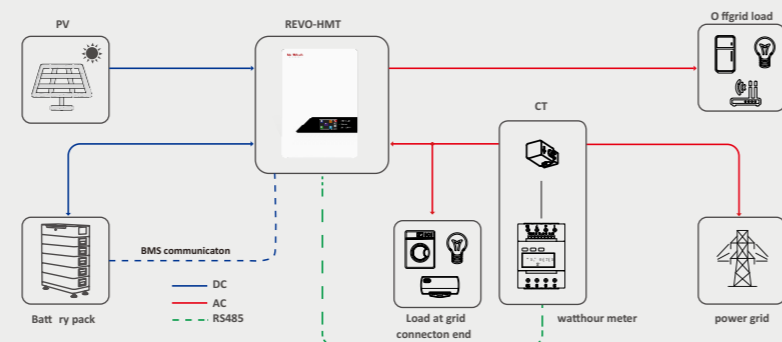

ENERGY STORAGE INVERTER



Technical Specification	REVO HMT series	
Rated Power	4000VA/4000W	6000VA/6000W
AC INPUT		
AC Voltage	230VAC	
Voltage Range	170-280VAC(For Personal Computers);90-280 VAC (For Home Appliances)	
Frequency Range	50Hz/60 Hz (Auto sensing)	
AC OUTPUT		
Surge power	8000VA	12000VA
Voltage regulation(Battery Mode)	230VAC±5%	
Rated frequency	50/60Hz	
Efficiency(Peak)	up to 93.5%	
Transfer Time	10ms (For Personal Computers);20ms (For Home Appliances);	
BATTERY		
Battery voltage	48VDC	
Floatng Charge voltage	54VDC	
Overcharge Protection	63VDC	
Battery type	Lithium /Lead-acid	
SOLAR CHARGER & AC CHARGER		
Maximum PV Array Open voltage(V)	500VDC	
Maximum PV Array power	5000W	6000W
MPPT voltage range(V)	90~450VDC	
Maximum input current	27A	
MPPT tracker/strings	1	
Maximum solar charge current	80A	120A
Maximum AC charge current	60A	100A
Maximum charge current	80A	120A
PROTECTION & FEATURE		
AC overcurrent	Yes	
AC overvoltage	Yes	
Over temperature protection	Yes	
Smart load management	Yes	
On Grid	Yes	
Parallel function	Yes,6 units	
GENERAL PARAMETER		
Operaton temperature	0°C~ 50°C	
Relative humidity	0 ~95%(non-condensing)	
Altitude	(> 2,000m Deratng)	
Dimensions D x W x H (mm)	315*140*525	
Net Weight(KG)	9	10.5
DISPLAY AND COMMUNICATION		
Display	Touch screen	
Interface	Standard:RS232,CAN&RS485 ; Optional: WiFi ,Bluetooth,CT	
Safety standard	EN/IEC 62109-1,EN/IEC 62109-2	

REVO HESS series HYBRID ALL-IN-ONE 6/8KW 10KWH



Simple
All-in-one design
modular installation
Quick plug connector battery module removable

On-Grid and Off-Grid
REVO HESS series is suitable for
on-grid and off-grid applications.

Safe
Physical and electrical dual isolation
BMS communication for lithium battery
With short circuit protection, over-voltage
protection, over load protection

Intelligent
Control and monitor your smart system on the
move via our monitoring APP and website

Product appearance drawing

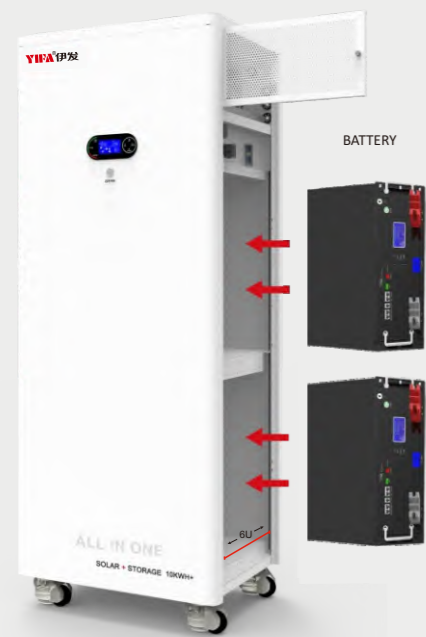

Wiring drawings



Product application diagram

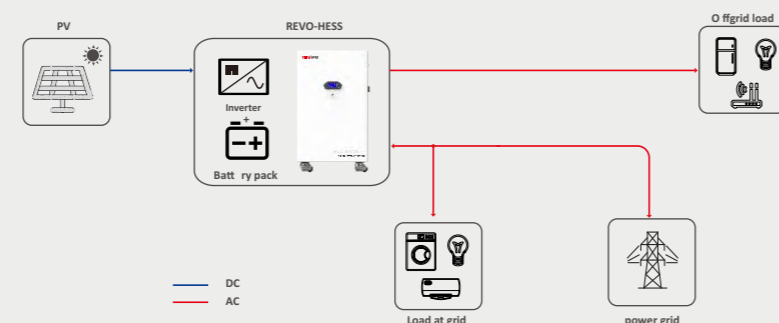

ALL IN ONE

Technical Specification	REVO HESS series	
Rated Inverter Power	6000VA/6000W	8000VA/8000W
AC INPUT		
Voltage	230VAC	
Selectable Voltage Range	170-280VAC(For Personal Computers);90-280 VAC (For Home Appliances)	
Frequency Range	50Hz/60 Hz (Auto sensing)	
AC OUTPUT		
Surge power	12000VA	16000VA
Voltage regulation(Battery Mode)	230VAC±5%	
Efficiency(Peak)	93%	
Transfer Time	10ms (For Personal Computers);20ms (For Home Appliances);	
Waveform	Pure Sine Wave	
No Load Power Consumption	> 75W	
BATTERY		
Capacity	5000Wh x 2	
Nominal Voltage	51.2VDC	
Full Charge Voltage(FC)	56V	
Full Discharge Voltage(FD)	42V	
Typical Capacity	100Ah x 2	
Max Continuous Discharging Current	100A x 2	
Max Discharging Current	192A at 1 min	
Protection	BMS, breaker	
Charge Voltage	56V	
Charge Current	20A(0.2C)	
Maximum Charge Current	50A(0.5C)	
Standard Charge Method	0.2C CC(Constant current)charge to FC,CV(Constant voltage FC) charge till charge current decline to ,0.05C	
Inner Resistance	> 20M ohm	
SOLAR CHARGER & AC CHARGER		
Solar Charger type	MPPT	
Maximum PV Array Power	6000W	8000W(4000Wx2)
MPPT Range @ Operating Voltage	90~450VDC	
Maximum PV Array Open Circuit Voltage	500VDC	
Maximum Solar Charge Current	120A	120A
Maximum AC Charge Current	100A	120A
Maximum Charge Current	120A	120A
GENERAL PARAMETER		
Dimensions W x D x H (mm)	552*452*1420	
Net Weight(KG)	55	

REVO HES series

Hybrid On & Off-Grid Energy Storage Solar Inverter 6-8KW



IP65 Rated

Engineered to last with maximum flexibility. Suitable for outdoor installation



On-Grid and Off-Grid

REVO HES series is suitable for on-grid and off-grid applications.



Easy access

Accessible through a LCD touch screen and through the web.



Remote Monitoring

Control and monitor your smart system on the move via our monitoring App and website



BMS

BMS Communication or lithium battery



Safe

Physical and electrical dual isolation, arth Leakage Current Monitoring, Anti-island protection, Insulation detection and so on



5 Years Warranty

Supplied with a full manufacturers warranty



Flexible Rate Tariff

Charge from the grid at off-peak time when energy is cheaper, and discharge at peak time when energy is more expensive.

Product characteristics

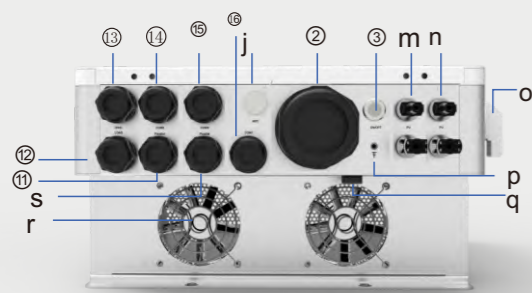

- ① WiFi port
- ② Battery port
- ③ Switch
- ④ PV port1
- ⑤ PV port2
- ⑥ PV switch(optional)
- ⑦ Ground
- ⑧ Breather valve
- ⑨ Fan
- ⑩ Parallel port
- ⑪ Parallel port
- ⑫ Load output
- ⑬ AC input
- ⑭ communication port
- ⑮ communication port
- ⑯ communication port

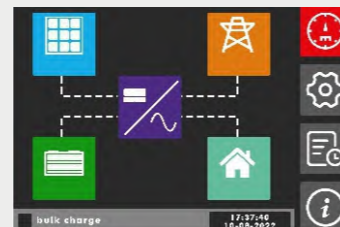

LCD touch screen

Circuit block diagram

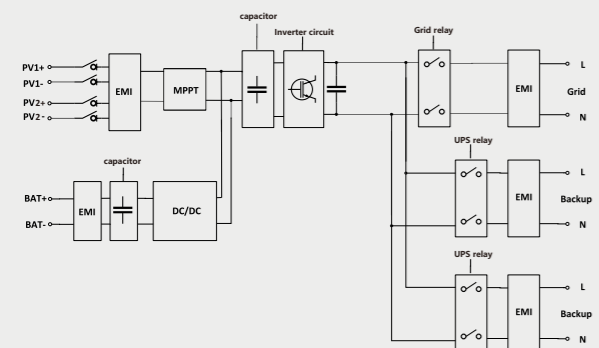

Product application diagram

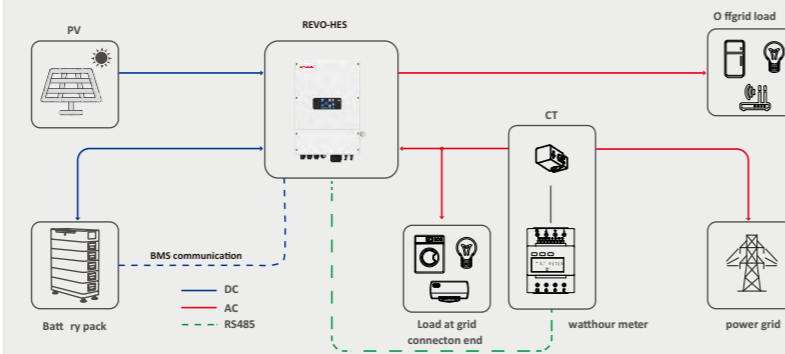

ENERGY STORAGE INVERTER | P 65

Technical Specification	REVO HES series	
PV INPUT		
Max. power(kW)	7.5	10
Max. DC voltage(V)	550	
MPPT voltage range(V)	90~450	
Max. short circuit current(A)	30	18+18
MPPT number/Max. input strings number	1/2	2/2
AC OUTPUT(GRID-TIED)		
Grid voltage(range(V))	230/176~270	
Frequency (Hz)	50 /60	
PF	0.8lagging-0.8leading	
THDi	<3%	
AC output topology	L+N+PE	
BATTERY		
Battery voltage range(V)	40~58	
Max. charging voltage(V)	58	
Max. charge/discharge current(A)	100/140	120/190
Battery type	Lithium /Lead-acid	
UPS OUTPUT		
Rated power (kw)	6	8
Rated output voltage(V)	220/230/240	
Rated output current(A)	25/27/27.2	33.3/34.7/36.3
Rated frequency (Hz)	50/60	
Transfer Time(ms)	<10	
THDu	<2%	
Overload capacity	110%, 30S/120%, 10S/150%, 0.02S	
PROTECTION & FEATURE		
Anti-island protection	Yes	
Insulation monitoring	Yes	
Residual current monitoring	Yes	
Arc fault protection	Yes(Optional)	
Parallel function	Yes, 6 units	
Other protection	AC overcurrent, AC overvoltage, Over temperature protection	
GENERAL PARAMETER		
Efficiency(Peak)	94%	
Degree of protection	IP 65	
Operation temperature	- 25°C~ 60°C, >45°C derating	
Cooling	smart cooling	
Relative humidity	0 ~95%(non-condensing)	
Altitude	(> 2,000m Derating)	
Dimensions W x D x H (mm)	360*195*660	
Net Weight(KG)	22.5	32
Isolation transformer	No	
Self-consumption(W)	<5	
DISPLAY AND COMMUNICATION		
Display	Touch screen	
Interface	Standard:RS232,CAN&RS485, Optional: Bluetooth, WiFi,CT	
Safety standard	EN/IEC 62109-1,EN/IEC 62109-2	

iHESS series 1P

Single Phase
Residential Energy Storage Inverter



Flexible Rate Tariff

Charge from the grid at off-peak times when energy is cheaper, and discharge at peak times when energy is more expensive.



Safe

Physical and electrical dual isolation
AFCI function Integration
AC overcurrent, AC overvoltage, Over temperature protection
IP 65 protection grade



Multiple working modes

iHESS series supports four working modes
1. Self Use 2. Time of Use
3. Backup Power 4. Grid Priority



Quick backup

Provides backup load with a transfer time less than 10 ms.

Product characteristics

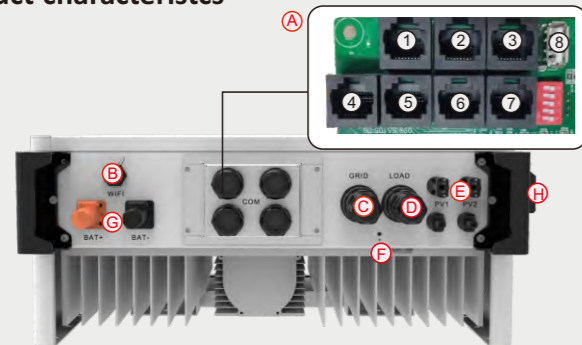

- A1: EPO/AFCI port
- A2: BMS port
- A3: Meter/CT port
- A4: Dry contact
- A5: DRM port
- A6: Parallel port
- A7: Parallel port
- A8: USB port
- B: WIFI port
- C: GRID port
- D: LOAD port
- E: PV port
- F: Breather valve
- G: Battery port
- H: PV Switch(optional)

Circuit block diagram

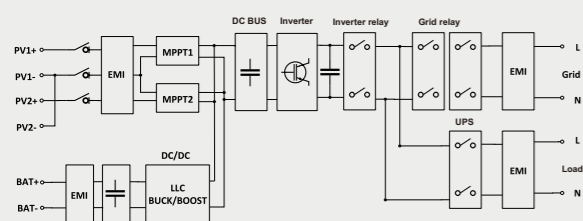

Product application diagram

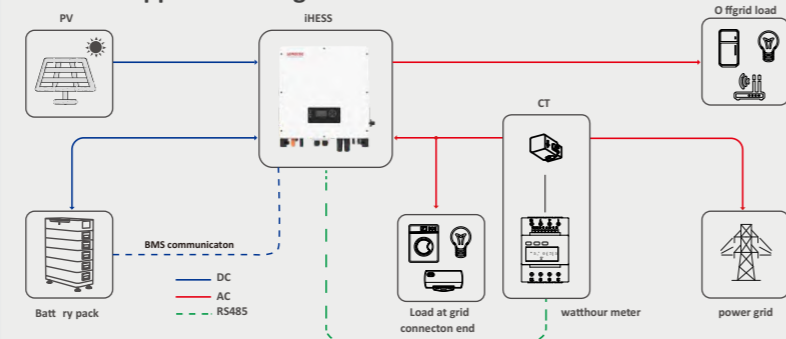

ENERGY STORAGE INVERTER | P65

Technical Specification	iHESS series			
EFFICIENCY				
DC Max. efficiency	97.50%			
Europe efficiency	97%			
PV INPUT				
Max. power(kW)	5.7	7	8	9.6
Max. DC voltage(V)	550			
MPPT voltage range(V)	90-500			
Max. input current of single MPPT(A)	16/16			
MPPT tracker/strings	2/1			
AC OUTPUT(GRID-TIED)				
Grid voltage/range(V)	230/176~270			
Frequency (Hz)	50 /60			
PF	0.8lagging-0.8leading			
THDi	<3%			
AC output topology	L+N+PE			
BATTERY				
Battery voltage range(V)	40~58			
Max. charging voltage(V)	58			
Max. charge/discharge current(A)	100/110			
Battery type	Lithium /Lead-acid			
UPS OUTPUT				
Rated power (kW)	3.6	4.6	5	6
Rated output voltage(V)	220/230/240			
Rated output current(A)	15/16/16.3	19.1/20/20.9	20.8/21.7/22.7	25/26/27.2
Rated frequency (Hz)	50/60			
Transfer Time(ms)	<10			
THDu	<2%			
Overload capacity	110%, 30S/120%, 10S/150%, 0.02S			
PROTECTION & FEATURE				
Anti-island protection	Yes			
DC Over current protection	Yes			
Insulation monitoring	Yes			
Residual current monitoring	Yes			
Arc fault protection	Yes(Optional)			
Battery reverse polarity protection	Yes			
Parallel function	Yes, 12 units			
Other protection	AC overcurrent, AC overvoltage, Over temperature protection			
GENERAL PARAMETER				
Degree of protection	IP65			
Operation temperature	- 25°C~ 60°C			
Cooling	Natural			
Relative humidity	0 ~95%(non-condensing)			
Altitude	(> 2,000m Derating)			
Dimensions W x D x H (mm)	480*210*495			
Net Weight(KG)	24.5			25
Isolation transformer	No			
Self-consumption(W)	<5			
DISPLAY AND COMMUNICATION				
Display	LCD			
Interface	Standard:RS485 ,CAN,DRM ; Optional:WiFi,Bluetooth			
Safety standard	CE-EMC/ENIEC 61000-6-3:2021,ENIEC61000-6-1:2019;CEVOC/IEC 62109-1:2010,IEC62109-2:2011,IEC 62477-1: 2022 COC/VDE4105:2018, VDE0124:2020; COC/CE10-21:2022; COC/TORTYPEA/B:2022, OVER25:2020; G98:2022, G99:2022			

iHESS 3P-H-EU series

Three Phase
Residential Energy Storage Inverter

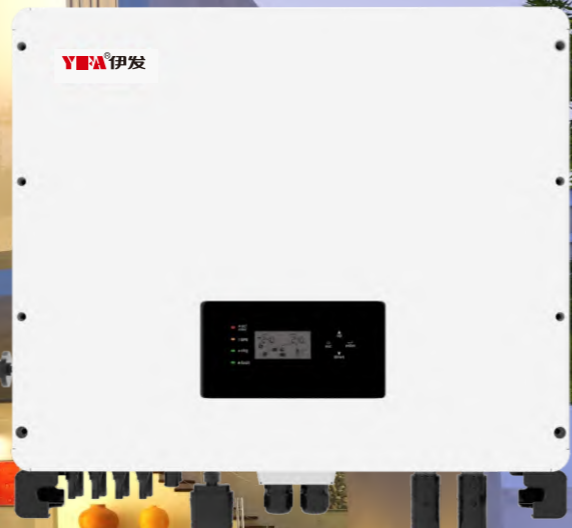

Flexible Rate Tariff

Charge from the grid at off-peak times when energy is cheaper, and discharge at peak times when energy is more expensive.



Safe

Physical and electrical dual isolation
AFCI function integration
AC overcurrent, AC overvoltage, Over temperature protection
IP 65 protection grade



Multiple working modes

iHESS series supports four working modes
1. Self Use 2. Time of Use
3. Backup Power 4. Grid Priority



Quick backup

Provides backup load with a transfer time less than 10 ms.

Product characteristics

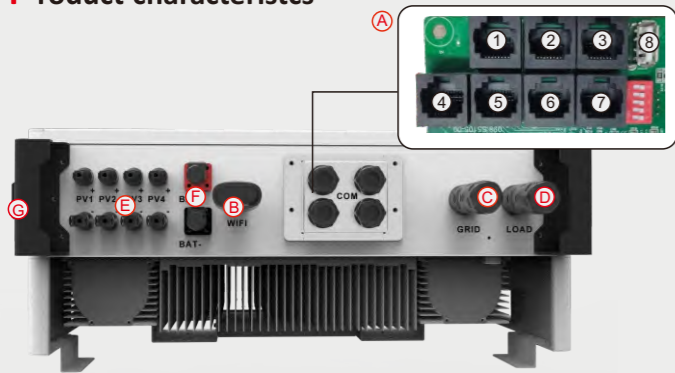

- A1: EPO/AFCI port
- A2: BMS port
- A3: Meter/CT port
- A4: Dry contact
- A5: DRM port
- A6: Parallel port
- A7: Parallel port
- A8: USB port
- B: WIFI port
- C: GRID port
- D: LOAD port
- E: PV port
- F: Battery port
- G: PV Switch(optional)

Circuit block diagram

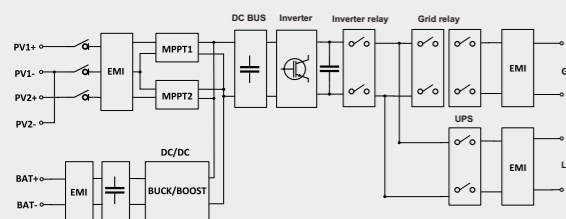

Product application diagram

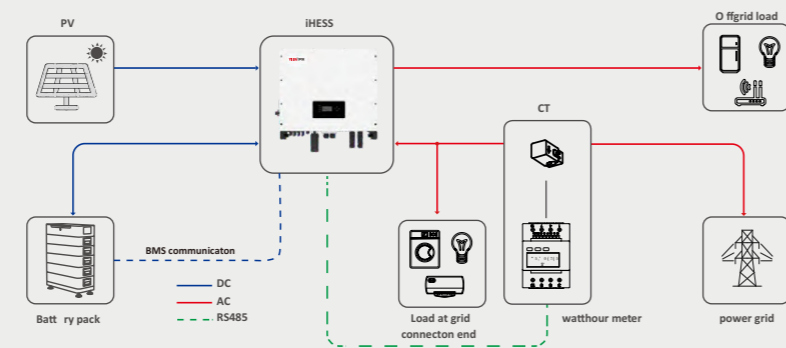

ENERGY STORAGE INVERTER | P65

Technical Specification	iHESS 3P series				
EFFICIENCY					
DC Max. efficiency	98.00%				
Europe efficiency	98%				
PV INPUT					
Max. power(kW)	8	9.6	12.8	16	19.2
Max. DC voltage(V)	1000				
MPPT voltage range(V)	180~900				
Max. input current of single MPPT(A)	16/16				
MPPT tracker/strings	2/1				
AC OUTPUT(GRID-TIED)					
Rated output power(kW)	5	6	8	10	12
Max. output current(A)	8	9.6	12.7	15.9	19.1
Grid voltage/range(V)	400/360~440				
Frequency (Hz)	50 /60				
PF	0.8lagging-0.8leading				
THDi	<3%				
AC output topology	3W+N+PE				
BATTERY					
Battery voltage range(V)	125-600				
Max. charging voltage(V)	600				
Rated battery voltage(V)	300				
Max. charge/discharge current(A)	40				
Battery type	Lithium /Lead-acid				
UPS OUTPUT					
Rated power (kW)	5	6	8	10	12
Rated output voltage(V)	400				
Rated output current(A)	8	9.6	12.7	15.9	19.1
Rated frequency (Hz)	50/60				
Transfer Time(ms)	<10				
THDu	<2%				
Overload capacity	110%, 30S/120%, 10S/150%, 0.02S				
PROTECTION & FEATURE					
Anti-Island protection	Yes				
DC Over current protection	Yes				
Insulation monitoring	Yes				
Residual current monitoring	Yes				
Arc fault protection	Yes				
Other protection	AC overcurrent, AC overvoltage, Over temperature protection				
Parallel function	Yes, 12 units				
GENERAL PARAMETER					
Degree of protection	IP65				
Operation temperature	- 25°C~ 60°C				
Cooling	Natural				
Relative humidity	0 ~95%(non-condensing)				
Altitude	(>2,000m Derating)				
Dimensions W x D x H (mm)	570*210*475				
Net Weight(KG)	28.5				
Isolation transformer	No				
Self-consumption(W)	<5				
DISPLAY AND COMMUNICATION					
Display	LCD				
Interface	Standard:RS485,CAN,DRM ; Optional:WiFi,Bluetooth				
Safety standard	CE-EMC/ENIEC 61000-6-3:2021,ENIEC61000-6-1:2019;CEVOC/IEC 62109-1:2010,IEC62109-2:2011,IEC 62477-1: 2022 COC/VDE4105:2018, VDE0124:2020 ;COC/CE10-21:2022 ;COC/TORTyPeA/B:2022, OVER25:2020 ;G98:2022, G99:2022				

iHESS-M series 1P Residential Energy Storage System ALL-IN-ONE

Power Inverters Expert

Inverter Module

Color

- a
- b
- c
- d

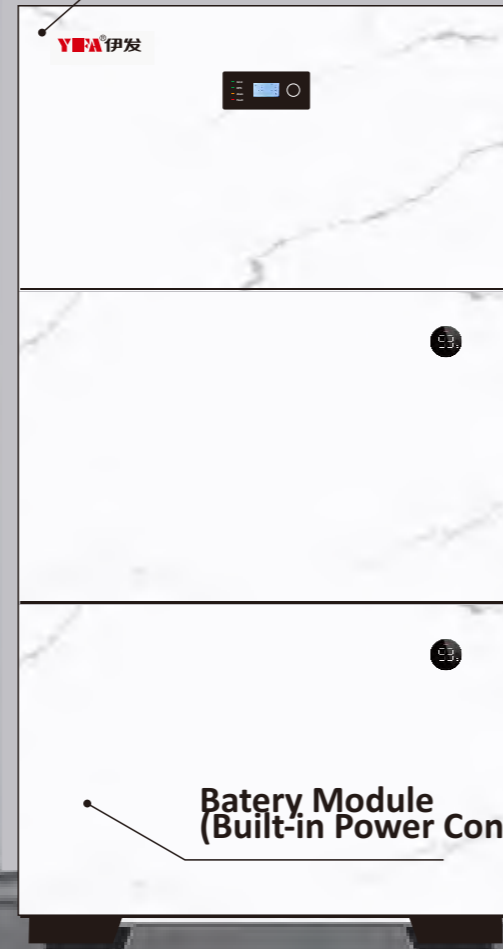

Battery Module
(Built-in Power Control Unit)

IP65 Rated
Engineered to last with maximum flexibility.
Suitable for outdoor installation

5 Years Warranty
Supplied with a full manufacturers warranty

Simple
All-in-one design
Modular installation
Quick plug connector battery module
removable

Safe
Sleep-class silence
Long battery life

Product application diagram

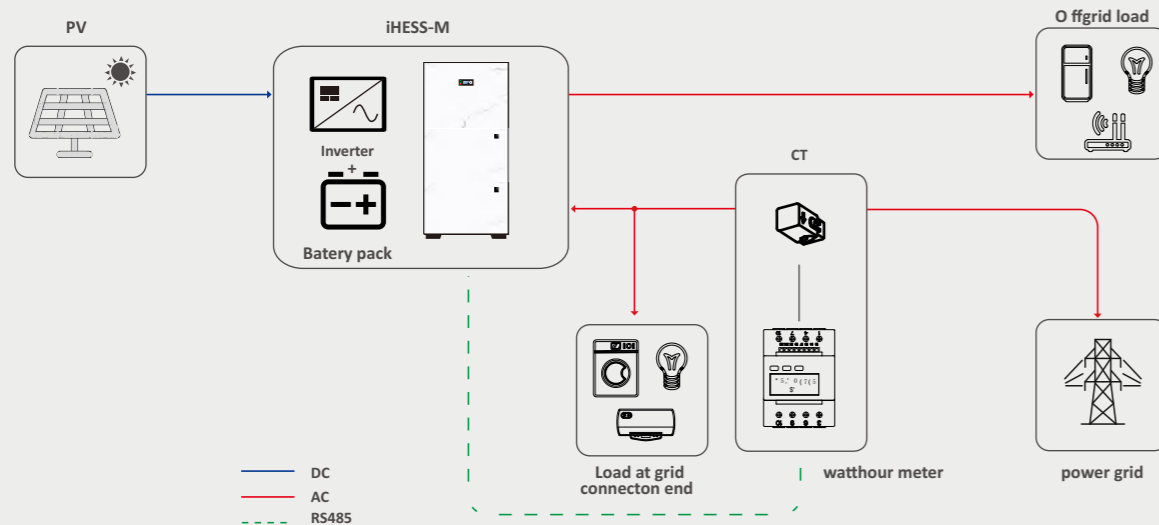

ENERGY STORAGE INVERTER I P65

Technical Specification	iHESS-M series
EFFICIENCY	
DC Max. efficiency	97.50%
Europe efficiency	97%
INPUT(PV)	
Max. power(kW)	9.6
Max. DC voltage(V)	550
MPPT voltage range(V)	90~500
Max.input current of single MPPT(A)	16/16
MPPT tracker/strings	2/1
AC OUTPUT	
Rated output power(kW)	6
Max. output current(A)	26
Grid voltage/range(V)	230/176~270
Frequency (Hz)	50 /60
PF	0.8lagging-0.8leading
THDi	<3%
AC output topology	L+N+PE
BATTERY	
Battery voltage range(V)	40~58
Max. charging voltage(V)	58
Max. charge/discharge current(A)	100/110
Battery type	Lithium /Lead-acid
EPS OUTPUT	
Rated power (kW)	6
Rated output voltage(V)	230
Rated output current(A)	26
Rated frequency (Hz)	50/60
Transfer Time(ms)	<10
THDi	<2%
Overload capacity	110%, 30S/120%, 10S/150%, 0.02S
PROTECTION& FEATURE	
Anti-island protection	Yes
DC overcurrent protection	Yes
Insulation monitoring	Yes
Residual current monitoring	Yes
Arc fault protection	Optional
Battery reverse polarity protection	Yes
Parallel Function	Yes,6 units
Other protection	AC overcurrent, AC overvoltage, Over temperature protection
BATTERY MODULE	
Model	SL-M48100
Battery type	LiFePo4
Battery module energy	5.12KWh
Max charge current&discharge current	100A
Dimensions W x D x H (mm)	640*200*400
Net Weight(KG)	54
GENERAL PARAMETER	
Degree of protection	IP65
Operaton temperature	- 25°C~ 60°C
Cooling	Natural
Relative humidity	0 ~95%(non-condensing)
Altitude	(> 2,000m Derating)
Dimensions W * D * H (mm)	480*210*495
Net Weight(KG)	25
Isolation transformer	No
Self-consumption(W)	<5
DISPLAY AND COMMUNICATION	
Display	LCD
Interface	Standard:RS485,CAN,DRM Optional:Wi fi,Bluetooth
Safety standard	CE-EMC/ENIEC 61000-6-3:2021,ENIEC61000-6-1:2019;CEVOC/IEC 62109-1:2010,IEC62109-2:2011,IEC 62477-1: 2022 COC/VDE4105:2018, VDE0124:2020; COC/CE10-21:2022; COC/TORTYPEA/B:2022, OVER25:2020; G98:2022, G99:2022

iHESS-M-H series 3P Residential Energy Storage System ALL-IN-ONE

Simple
All-in-one design
Modular installation & Quick plug connector

Independent
Real uninterruptible power supply, transfer time < 10ms

Modular
Modular and integrated design for easy transportation and installation

Battery
More available battery energy with pack optimization
Batteries flexible expansion in stages

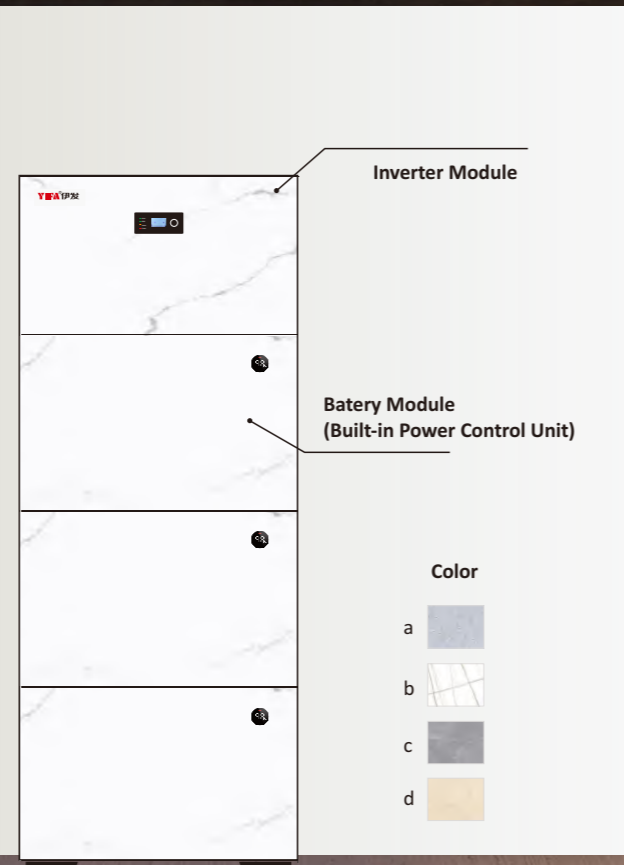

P roduct application diagram

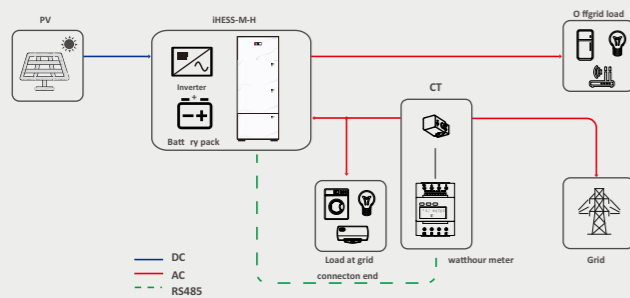

S chematic diagram

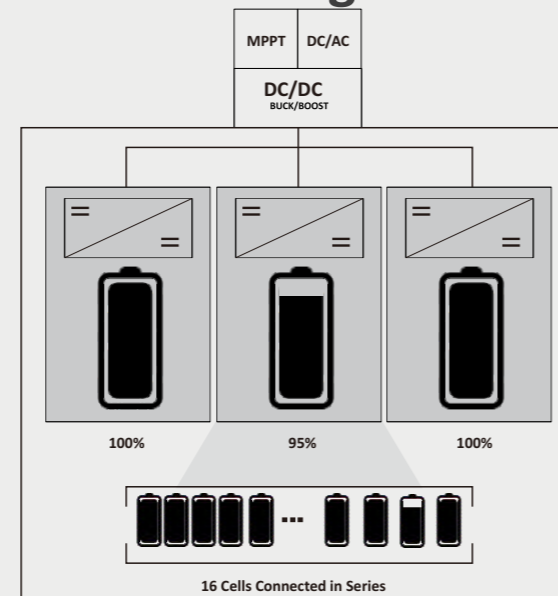

ENERGY STORAGE INVERTER | P65

Technical Specification	iHESS-M-H series 3P				
Rated output power	5/6/8/10/12 kW				
Quantity of batteries	1-6				
Battery total energy	5.12kWh~30.72kWh				
Usable Energy	4.75kWh~28.5kWh				
Degree of protection	IP65				
Ambient temperature range	-10°C~+45°C				
Allowable relative humidity range	5%~95%				
Max. operating altitude	4000m				
Cooling type	Natural cooling				
Installation method	Floor or Wall-mounted (optional)				
Display	LCD & APP+Bluetooth				
Noise	< 25dB				
Communication	RS485/Bluetooth/Ethernet, Optional: WiFi/4G/GPRS				
INVERTER MODULE					
Model	5kw	6kw	8kw	10kw	12kw
Battery voltage range	300-435VDC				
Rated battery voltage	384V				
Max. charge/discharge current	40A				
Recommended Max. PV input power	8000wp	9600wp	12800wp	16000wp	19200wp
Max. input voltage	1000V				
MPPT operating voltage range	180~900V				
Number of MPPT trackers	2				
Max. input current per MPPT	13A/13A				
Rated grid voltage	400V 3W/N/PE, 50Hz/60Hz				
Grid voltage range	360-440V				
Rated AC power	5kw	6kw	8kw	10kw	12kw
Max. AC power output to utility grid	5kw	6kw	8kw	10kw	12kw
Rated voltage, Frequency (Off-grid)	400V 3W/N/PE, 50Hz/60Hz				
Max. apparent power (Off-grid)	5000VA	6000VA	8000VA	10000VA	12000VA
Transfer time	< 10ms				
Max efficiency of solar inverter	98.00%				
European efficiency of solar inverter	98.00%				
Topology	Transformerless				
Dimensions W x D x H (mm)	640*200*595				
Net Weight (KG)	28.5				
BATTERY MODULE					
Model	SL-HM 100				
Voltage range	300~435VDC				
Battery Type	LiFePO4				
Battery module energy	5.12kWh				
Depth of discharge (DOD)	0~90% adjustable				
Rated Power	3000W				
Topology	Transformer isolation				
Dimensions W x D x H (mm)	640*200*400				
Net Weight (KG)	55				
STANDARD					
EMC	EN 61000-6-2, EN 61000-6-3, EN 61000-3-2, EN 61000-3-3, EN 61000-3-11, EN 61000-3-12				
Safety standards	CE-EMC/ENIEC 61000-6-3:2021, ENIEC61000-6-1:2019, CEVOC/IEC 62109-1:2010, IEC62109-2:2011, IEC 62477-1: 2022 COC/VDE4105:2018, VDE0124:2020, COC/CE10-21:2022, COC/TORTTypeA/B:2022, OVER25:2020, G98:2022, G99:2022				
Grid standards	VDE-AR-N 4105, VDE V 0126-1-1, CEI 0-21, G98/G99, EN 50438/EN50549				

MPG-M series

Energy Storage Converter



Flexible configuration

Compact size, standard cabinet width design
Support DCDC (PV), ATS device access



Efficient and stable

No fragile parts, modular N+1 redundancy
System online rate 99%



Perfect compatibility

150~750V Extra Wide Voltage Range
Supports lead acid/lithium/sodium ion batteries



Safe

Support linking with BMS, EMS systems
System has multiple protection

Product application diagram

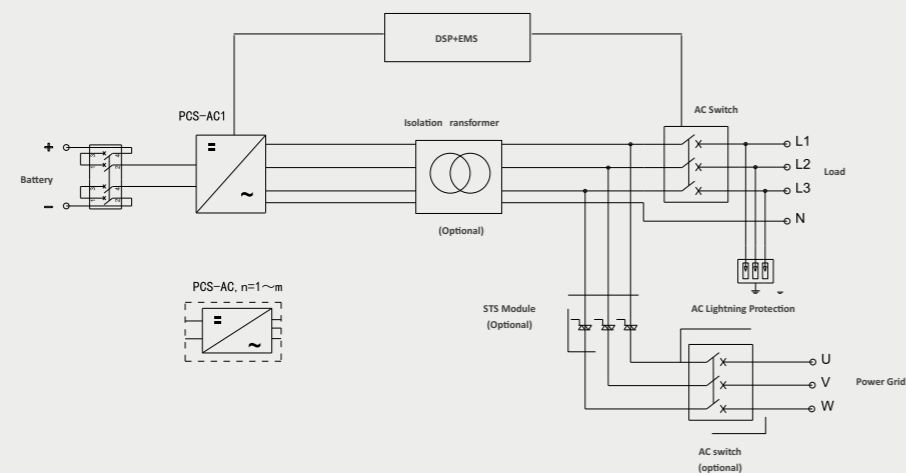

Technical Specification	MPG-M series		
AC PARAMETERS			
Rated AC Power	50KVA	75KVA	120KVA
Allowable Voltage	380/400(±15%)VAC		
Allowable Frequency	50/60(±2.5)Hz		
THDi	≤3%		
Power factor	0.99/-1~1		
Overload capacity	55KVA	82.5KVA	144KVA
Wiring method	three-phase four-wire		
Isolation transformer	NO		
DC PARAMETERS(BATTERY)			
Battery voltage range	600~900VDC		
Max.DC current	80A	125A	200A
PROTECTION &FEATURES			
DC input switch	support		
Ant-Islanding protection	support		
Output overcurrent protection	support		
DC surge protection	Type II		
AC surge protection	Type II		
Insulation resistance testing	support		
Leakage current protection	support		
SYSTEM PARAMETER			
Maximum efficiency	98%		
Dimensions W x D x H (mm)	440*173*550		
Net Weight(KG)	320	580	830
Noise	<75dB		
Protection grade	IP20		
Allowable ambient temperature	-20°C		
Humidity	0 to 95% (non condensing)		
Altitude	(>3,000m Derating)		
Cooling mode	Air cooling		
COMMUNICATION PARAMETERS			
Display	LCD display		
Communication interface	RS485/CAN		
Communication protocol	ModbusTCP/RTU, IEC104, IEC61850		
BMS access	Support		

MPGS Series

On & Off-Grid Energy Storage Inverter
Integrated Machine



Solar
Built in MPPT, which can be directly connected to photovoltaic panels. Input range of PV up to 900V

Quick Switcher
UPS uninterruptible power supply function
Offline transfer time < 10ms

Easy access
Easy to operate by touching the LCD screen

On-Grid and Off-Grid
It has its own optimal storage operation strategy, which is deployed on demand and supports self use

Safe
Support connection with BMS and EMS systems

Flexible Rate Tariff
With peak and valley energy management
With PV+mains load mode
PV+battery load mode

INDUSTRIAL AND COMMERCIAL ENERGY STORAGE INVERTER



Technical Specification	MPGS Series						
AC PARAMETERS							
Rated AC Power	50KVA	100KVA	150KVA	200KVA	300KVA	500KVA	600KVA
Allowable Grid Voltage	380/400(±15%)VAC						
Allowable Grid Frequency	50/60(±2.5)Hz						
THDi	≤3%						
Power factor	0.99/-1~1						
Overload capacity	55KVA	110KVA	165KVA	220KVA	330KVA	550KVA	660KVA
Wiring method	three-phase four-wire						
Isolation transformer	Optional						
DC PARAMETERS(BATTERY)							
Battery Voltage Range	600~900VDC						
Maximum Charging Current	150A	300A	450A	600A	900A	1500A	1800A
DC PARAMETERS(PHOTOVOLTAIC)							
Maximum Photovoltaic Input Voltage	1000VDC						
Maximum Photovoltaic Power	55KW	110KW	165KW	220KW	330KW	550KW	660KW
MPPT Voltage Range	200~850VDC						
PROTECTION & FEATURES							
DC Input Switch	YES						
Anti-island Protection	YES						
Output Overcurrent Protection	YES						
DC Surge Protection	Type II						
AC Surge Protection	Type II						
Insulation Impedance Test	YES						
Leakage Current Protection	YES						
SYSTEM PARAMETER							
Maximum Efficiency	98%						
Dimensions W x D x H (mm)	800*2160*800		1200*2160*800		1600*2160*800		
Net Weight(KG)	520	750	900	1350	2860	3230	3650
Noise	<75dB						
Degree Of Protection	IP20						
Allowable Ambient temperature	-20°C						
Humidity	0~95% (non condensing)						
Altitude	(>3,000m Derating)						
Cooling Mode	Air cooling						
COMMUNICATION PARAMETERS							
Display	Touch LCD Display						
Communication Interface	RS485/CAN(Optional)						
BMS Access	YES						
CT anti-reflux prevention function	YES						

Product application diagram

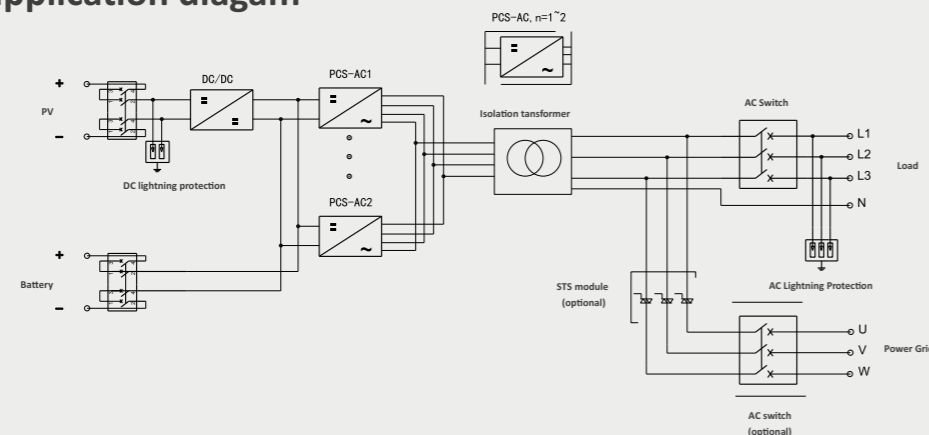

MPG series

Energy Storage Converter

100-1200KVA



Flexible Configurraon

Three-level modular design, two-way energy conversion
Optional STS device to realize seamless switching between grid and off-grid



Efficient and stable

Each module operates independently, and the system online rate is 99%
Support 1/4 branch circuit battery access which avoid direct parallel connection of baary packs and effecccvely solve circualon problems



Intelligent Collaboraton

With active and reactive power four-quadrant adjustment function, with automaac operaron strategy for peak shaving and valley filling, with VSG virtual synchronous machine technology



Grid friendly

With LVRT and HVRT functions
With active and reactive power four-quadrant adjustment function
With accurate switching function of power source , network and load

Product application diagram

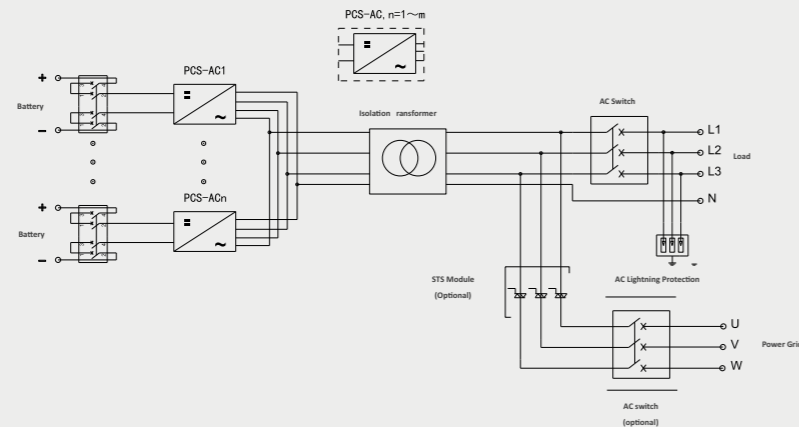

Technical Specifcaaoon	MPG Series 100-1200									
AC PARAMETERS										
Rated AC Power	100KVA	200KVA	300KVA	400KVA	500KVA	600KVA	800KVA	1000KVA	1200KVA	
Allowable Grid Voltage	380/400(±15%)VAC									
Allowable Grid Frequency	50/60(±2.5)Hz									
THDi	≤3%									
Power factor	0.99/-1~1									
Overload capacity	110KVA	220KVA	330KVA	440KVA	550KVA	660KVA	880KVA	1100KVA	1320KVA	
Wiring method	three-phase four-wire									
Isolaton transformer	Optional									
DC PARAMETERS(BATTERY)										
Batery Voltage Range	600~900VDC									
Number of DC access circuits	1/2/4/5/8									
Maximum Charging Current	150A	300A	450A	600A	880A	1100A	1400A	1700A	2200A	
PROTECTION & FEATURES										
DC Input Switch	YES									
Ant-island Proteccion	YES									
Output Overcurrent Protecton	YES									
DC Surge Protecton	Type II									
AC Surge Protecton	Type II									
Insulaton Impedance Test	YES									
Leakage Current Protecton	YES									
SYSTEM PARAMETER										
Maximum Efficiency	98%									
Dimensions W x D x H (mm)	800*2160*800					1100*2160*800				
Net Weight(KG)	180	245	320	410	550	580	660	750	830	
Noise	<75dB									
Degree Of Protecton	IP20									
Allowable Ambient temperature	0~95% (non condensing)									
Humidity	-20°C									
Alttude	(>3,000m Deratng)									
Cooling Mode	Air cooling									
COMMUNICATION PARAMETERS										
Display	Touch LCD Display									
Communicaton Interface	RS485/CAN									
Communicaton Protocol	ModbusTCP/RTU,IEC104,IEC61850									
BMS Access	YES									

SES series

Energy storage converter



Simple and flexible

High integrator, small size, easy installation, operation and maintenance
IP54 protection grade



Economical & friendly

Reducing the maximum demand electricity cost, with considerable economic benefits



Safe and reliable

Built-in fire extinguishing, temperature control, early warning system multiple security guarantees

INDUSTRIAL AND COMMERCIAL ENERGY STORAGE CONVERTER

Technical Specification	SES Series
DC DATA	
Battery capacity (kWh)	100~200
Number of battery racks	1~2
BMS communication interface	RS485/CAN
DC voltage range(V)	420~850
AC DATA	
Rated AC power(kW)	30~150
Max. AC power(kW)	30~150
Rated AC current(A)	43~216
Max. AC current(A)	48~238
DC current component	< 0.5%
THDi	< 3% (Rated power)
Rated grid voltage(V)	400
Allowable grid voltage range(V)	320~460
Rated grid frequency(Hz)	50/60
Allowable grid frequency range(Hz)	45~55/55~65
Power factor	1lagging-1leading
Isolation method	With the isolation
GENERAL DATA	
Ingress protection	IP54
Fire extinguishing system	Support
Operating temperature	-30°C~ 55°C
Dimensions W x D x H (mm)	Customization*1,300*2,400
Net Weight(KG)	Customization
BMS communication mode	CAN, RS485
EMS communication mode	RS485, TCP/IP
PCS cooling way	Temperature control intelligent air cooling
Battery cooling way	Air conditioning cooling
Altitude	(>3,000m Derating)

Product application diagram

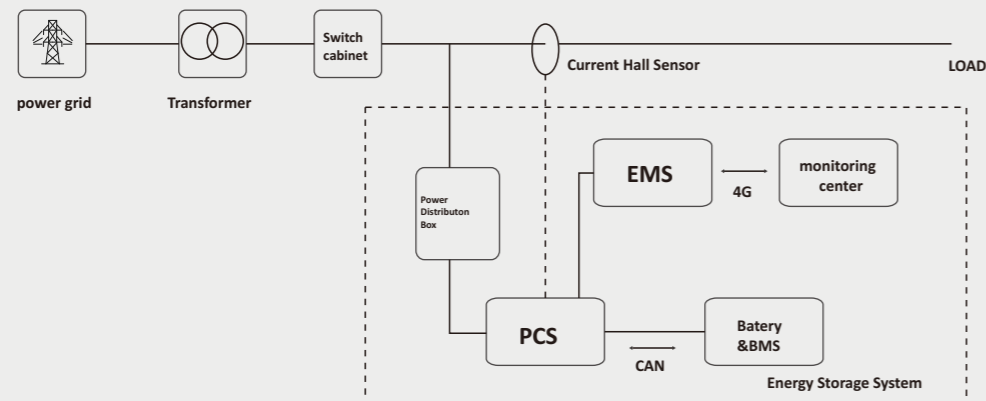



SL-W SL-R Series
LiFePO₄ Battery
100AH-200AH

ENERGY STORAGE BATTERY



Technical Specification	SL 25.6100	SL 25.6200	SL 48100	SL 48200	SL 51.2100	SL 51.2200
Case design	Stand by the wall & Hang on the wall					
Battery Type	LiFePO ₄					
Nominal Battery Model	25.6V100AH	25.6V200AH	48V100AH	48V200AH	51.2V100AH	51.2V200AH
Nominal Capacity(25°C,0.2C)	2560Wh	5120Wh	4800Wh	9600Wh	5120Wh	10240Wh
Voltage range(Vdc)	20~29.4V		40~58.4V			
Float Charge Voltage(Vdc)	27.6V		55.2V			
Max Continuous Discharge Current(A)	100A					
Max Continuous charge Current(A)	50A					
Cycle life,+25°C,0.2C 100% DOD	> 6000Cycles					
Storage temperature	-20°C~45°C					
Storage duration	3 months at 25°C					
Degree of protection	IP20					
Communication	CAN/RS485/RS232,standard BMS with SOROTEC Inverters Communication protocol					
PROTECTION						
Protection	Overcurrent protection ,overdischarge protection,short circuit protection, overcharge protection					
AMBIENT						
Working Temperature	Discharge:-20°C~+65°C Charge:0°C~+45°C					
Humidity	0~95%(no condensaton)					
Dimensions W x D x H (mm)	460*195*642	460*195*642	460*223*641.5	460*223*641.5	460*214.5*923.5	460*214.5*923.5

Product Snapshot

- 6000 cycle times, 5 years warranty, 10+years life design
- Power wall design ,space saving design
- High density,small size and weight
- LCD display with communication port(CAN/ RS485/RS232)
- Multi-pottection
- Optional smart BMS can communicate with different brand of Hybrid Solar Inverter

SL-W-EU series LiFePO₄ Battery



Color

- a
- b
- c
- d

ENERGY STORAGE BATTERY

Technical Specification	SL-W-EU 48100	SL-W-EU 48200
Case design	Stand by the wall & Hang on the wall	
Battery Type	LiFePO ₄	
Nominal Battery Model	51.2V100AH	51.2V200AH
Nominal Capacity(25°C,0.2C)	5120Wh	10240Wh
Voltage range(Vdc)	40~58.4V	
Float Charge Voltage(Vdc)	55.2V	
Max Continuous Discharge Current(A)	100A	
Safety standard	UN38.3 MSDS	
Cycle life,+25°C,0.2C 100% DOD	> 6000Cycles	
Storage temperature	-20°C~45°C	
Storage duration	3 months at 25°C	
Degree of protection	IP65	
Communication	CAN/RS485/RS232,standard BMS with SOROTEC Inverters Communication protocol	
System Connection	Max.10 pcs parallel	
PROTECTION		
Protection	Overcurrent protection ,overdischarge protection,shortcircuit protection, overcharge protection	
AMBIENT		
Working Temperature	-10°C~+50°C	
Humidity	0~95%(no condensaton)	
Net Weight(KG)	47	90
Dimensions W x D x H (mm)	195*460*550	235*460*860

Product Snapshot

- Compact size and easy installation
- High energy density and efficiency
- Excellent safety of LifePo₄ battery
- Single person can carry and install it. Plug and play quick installation
- Adopt the mineral color appearance design, lead the fashion
- Long lifespan, 10 years warranty



SL-S-EU Series LiFePO₄ Battery

- Color
- a
 - b
 - c
 - d

Technical Specification	SL-S-EU 48100									
System Demo										
Number of Modules	1	2	3	4	5	6	7	8	9	10
Energy Capacity(kwh)	2.56	5.12	7.68	10.24	12.8	15.35	17.92	20.48	23.04	25.64
Usable Capacity(kwh)	2.30	4.6	6.9	9.21	11.52	13.81	16.12	18.43	20.73	23.04
Dimensions W x D x H (mm)	620*260 * 185	620*260 * 335	620*260 * 485	620*260 * 635	620*260 * 785	620*260 * 935	620*260 * 1085	620*260 * 1235	620*260 * 1385	620*260 * 1535
Net Weight(KG)	28	56	84	112	140	168	196	224	252	280
Standard Charge/Discharge Current	25A	50A	75A	100A						
GENERAL										
Battery Type	Cobalt free Lithium Iron Phosphate(LFP)									
Nominal Voltage	51.2V									
Operating Voltage Range	47.2-56.8V									
Degree of protection	IP65									
Installation	Wall-mounted or Floor installation*1									
Operating Temperature	-10~50°C*2									
FEATURES										
BMS Monitoring parameters	SOC, System voltage, current, cell voltage, cell temperature, PCBA temperature measurement									

Product Snapshot

- Excellent safety of cobalt free LifePo4 battery
- Easy installation with modular and tacked design
- Single person can carry and install it. Plug and play quick installation
- Adopt the mineral color appearance design, lead the fashion

SHW48500 series Solar Power System for Telecom Station

50-1000A



Rectifier Module



MPPT Solar Controller Module



Monitor



Flexible configuration

Modular design, flexible configuration, easy expansion. Monitoring network flexibility, providing RS232 interface, and trunk connectors.



Intelligent collaboration

Detect machine operation parameters and control parameters. Adjust battery undervoltage, overload, overcharge.



Efficient and stable

DC/DC Conversion, MPPT, Battery Constant Current, Equal Charge, Temperature Compensation Function.

Product application diagram

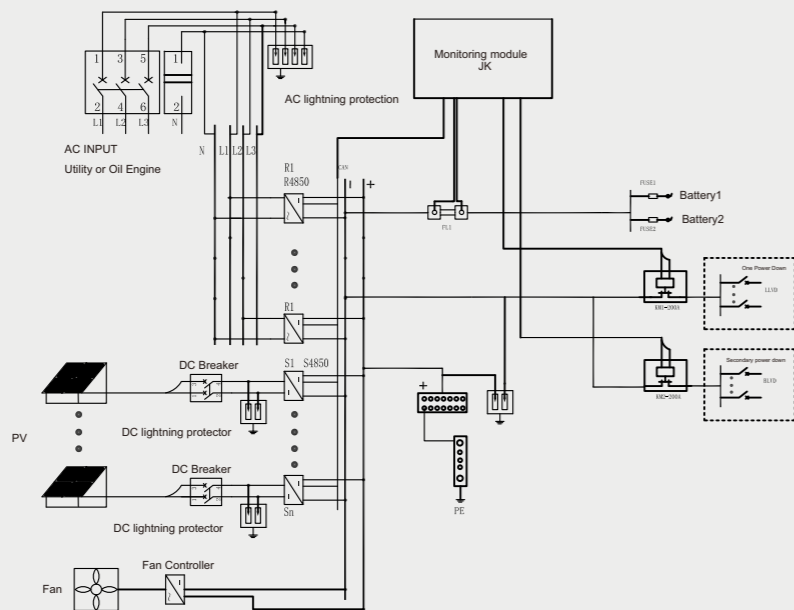

SHW48500

YIFA 伊发

Technical Specification	SHW48100	SHW48200	SHW48300	SHW48400	SHW48500
Capacity	100A	200A	300A	400A	500A
AC INPUT					
Input System	Three-phase, five-wire system/compatible single-phase				
Rated input voltage	Line voltage 380Vac/single phase 220Vac				
Input Voltage Range	85Vac ~ 290Vac				
Input AC Voltage Frequency	45Hz~65Hz				
Maximum input current	≤55A(Single-phase)				
Power factor	≥0.99				
SOLAR ENERGY INPUT					
Rated input voltage	68Vac				
Input Voltage Range	60Vdc~150Vdc				
Maximum input current	≤62A(One way)				
DC OUTPUT					
Output DC Voltage Range	42Vdc~58Vdc				
Output DC Voltage	54.0V				
Output DC Current	0~50A(Single module)				
Conversion efficiency	More than or equal to 95% in only power mode; 96% in only PV mode				
COMMUNICATION MANAGEMENT					
R S232 Interface/RS485 Interface	Configurable wireless monitoring module (for remote monitoring)				
LOAD MANAGEMENT					
Disconnect at a time	46.6V(40V-50V Setable)				
Second Disconnect	45.6V(40V-52V Setable)				
ENVIRONMENT CONDITION					
Working temperature	- 20°C~+55°C				
Storage temperature	- 40°C~+70°C				
Relative humidity	5%RH~90%RH				
Altitude	(>3,000m Derating)				
Other	No conductive dust, no corrosive gas, no explosion risk				
ENVIRONMENT CONDITION					
Cabinet (wide x deep x high)	600*600*1200				
User Device Space(mm)	4U high, 19 inch wide				
Solar module(mm)	42 (1U wide)*285 (deep, without handle)*135 (3U high)				
Rectifier module(mm)	85.3 (2U wide)*287 (deep, without LOGO)*132.3 (3U high)				
Cabinet (kg)	82 (excluding rectifier module, monitoring unit)				
Solar module(kg)	3				
Rectifier module(kg)	3.5				